

Lynx Smart BMS

500A and 1000A (M10)

www.victronenergy.com



Lynx Smart BMS 500 A



Lynx Smart BMS 1000 A

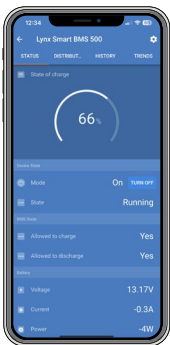

VictronConnect

System example – Lynx Smart BMS, 2x Lynx Distributor and lithium batteries

This system contains the following components:

- Lynx Distributor with 2 fused paralleled Lithium Smart batteries.
- Lynx Smart BMS with BMS, contactor and battery monitor.
- A second Lynx Distributor provides fused connections for inverter/charger(s), loads and chargers. Additional modules can be added if more connections are needed.
- A Cerbo GX (or other GX device) to read out the Lynx Smart BMS and Lynx Distributor data.

The Lynx Smart BMS is a dedicated Battery Management System (BMS) for the [Victron Lithium Battery Smart](#) batteries. These batteries are Lithium Iron Phosphate (LiFePO₄) batteries and are available in 12.8 V or 25.6 V in various capacities. They can be connected in series, parallel and series/parallel so that a battery bank can be built for system voltages of 12V, 24 V or 48 V. The maximum number of batteries in one system is 20, which results in a maximum energy storage of 84 kWh in a 12 V and up to 102 kWh in a 24 V¹⁾ and 48 V¹⁾ system.

For more information on these batteries, visit the [Victron Lithium Battery Smart product page](#).

Out of the various available BMSes, the Lynx Smart BMS is the most feature rich and complete option and integrates seamlessly into the [Lynx Distributor system](#). It is available in 500 A (M8) and 1000 A (M10) versions.

Built-in 500 A or 1000 A contactor

The contactor acts as a secondary safety system to protect the battery in case the primary controls (ATC, ATD and/or DVCC) fail to disable loads and/or chargers when required and is also suitable as a remote controllable main system switch.

Pre-charge circuit

In addition to the contactor, a built-in pre-charge circuit prevents high inrush currents when connecting a capacitive load such as a MultiPlus/Quattro or other inverter, eliminating the need for external pre-charging.

Monitoring and control

Monitor and control the BMS via Bluetooth using the [VictronConnect App](#) or a GX device such as a [Cerbo GX](#) and the [VRM Portal](#). A built-in battery monitor that operates in a similar fashion as the other [Victron Energy battery monitors](#), provides data such as state of charge, voltage, current, historical data, status info and more in real time, and with [Instant Readout](#) even without the need to connect to the BMS, allowing diagnostic at a glance.

DVCC closed loop control as well as ATC/ATD contacts

Compatible Victron inverter/chargers and solar chargers are automatically controlled via a connected GX device and [DVCC](#). The ATC/ATD contacts can be used to control other chargers and loads that have a remote on/off port.

Programmable relay

The relay can be used either as an alarm relay (combined with the pre-alarm) or to control an alternator via its external regulator (ignition cable). In Alternator ATC mode, the relay will only activate when the contactor is closed. Alternator ATC contact of the alternator opens first and then with a delay of 2 seconds the contactor. These 2 seconds ensure that the alternator is switched off before the battery is disconnected from the system.

AUX terminal

The advantage of the onboard auxiliary power supply (1.1 A @ system voltage) is to provide power to specific loads (i.e. a GX device) after the BMS has shut down the loads in the event of a low cell voltage event. If no charge voltage is detected within 5 minutes, the BMS including the AUX connection switches off.

VE.Can and NMEA 2000 data communication

VE.Can allows for easy connection (standard RJ45 network cable) and communication with a GX device. Since the CANbus protocol is based on NMEA 2000 (and J1939), it is easy to integrate into a marine network and feed your marine MFD with data (requires a [VE.Can to NMEA 2000 micro-C male cable](#)).

Lynx Distributor fuse monitoring

Read out fuse status and receive an alarm in case a fuse is blown. The Lynx Smart BMS monitors up to 4 connected Lynx Distributors and their fuses via VictronConnect or a GX device

¹⁾ To reduce required balancing time, we recommend to use a little different batteries in series as possible for the application. 24 V systems are best built using 24 V batteries. And 48 V systems are best built using two 24 V batteries in series. While the alternative, four 12 V batteries in series, will work, it will require more periodic balancing time.

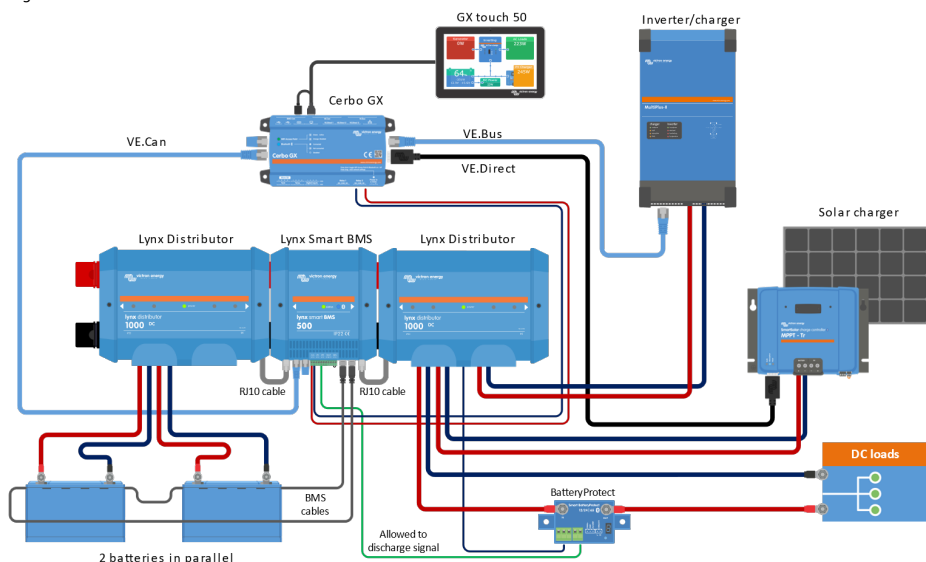

Lynx Smart BMS	500 A (LYN040102100)	1000 A
POWER		
Battery voltage range	9 – 60 VDC	
Maximum input voltage	75 VDC	
Supported system voltages	12, 24 or 48 V	
Reverse polarity protection	No	
Main safety contactor continuous current rating	500 A continuous	1000 A continuous
Main safety contactor peak current rating	600 A for 5 minutes	1200 A for 5 minutes
Power consumption OFF mode	0.3 mA for all system voltages	
Power consumption in Standby mode	Approximately 0.6 W (50 mA at 12 V)	
Power consumption in ON mode	Approx. 2.6 W (217 mA at 12 V) depending on the state of the relays	Approximately 4.2 W (350 mA at 12 V) depending on the state of the relays
Minimum load resistance for pre-charging	10 Ω and above for 12 V systems 20 Ω and above for 24 V and 48 V systems	
AUX output maximum current rating	1.1 A continuous, protected by resettable fuse	
Allow-to-charge port Maximum current rating	0.5 A at 60 VDC, protected by resettable fuse	
Allow-to-discharge port Maximum current rating	0.5 A at 60VDC, protected by resettable fuse	
Alarm relay (SPDT) Maximum current rating	2 A at 60 VDC	
CONNECTIONS		
Busbar	M8 (Torque: 14 Nm)	M10 (Torque: 33 Nm) (17 Nm for units with a serial number before HQ2340XXXX)
VE.Can	RJ45	
I/O	Removable multi-connector with screw terminals	
Battery BTV cables	Male and female circular 3-pole connector with M8 screw ring Up to 20 batteries can be connected in one system	
Lynx Distributor fuse monitoring (up to 4 modules)	RJ10 (cable ships with each Lynx Distributor)	
PHYSICAL		
Enclosure material	ABS	
Enclosure dimensions (h x w x d)	190 x 180 x 80 mm	230 x 180 x 100 mm
Unit weight	1.9 kg	2.7 kg
Busbar material	Tinned copper	
Busbar dimensions (h x w)	8 x 30 mm	
ENVIRONMENTAL		
Operating temperature range	-40 °C to +60 °C	
Storage temperature range	-40 °C to +60 °C	
Humidity	Max. 95 % (non-condensing)	
Protection class	IP22	
STANDARDS		
Safety	EN-IEC 63000:2018	
EMC	EN-IEC 61000-6-3:2007/A1:2011/AC:2012	
QMS	NEN-EN-ISO 9001:2015	

