

**3.87**  
kWh

**PHI™**  
**3.8-M Battery**



**BRIGGS & STRATTON**  
ENERGY SOLUTIONS



Certified to UL 9540  
and UL 9540A  
Fire Safety Tested



The **PHI™ 3.8-M Battery** utilizes advanced Lithium Ferro Phosphate (LFP) chemistry that eliminates cobalt which reduces the risk of thermal runaway, fire propagation, operating temperature constraints, and toxic coolants. When combined with our integrated high-performance Battery Management System (BMS), accessible 80A DC breaker On/Off switch and overcurrent protection (OCPD), the PHI 3.8-M Battery delivers safer, highly efficient and cost-effective service over the life of both residential and commercial installations, on or off-grid. Compatible with all industry standard inverter charge controllers, the PHI 3.8-M Battery supports balance-of-system equipment and optimizes any power generation source - solar, wind, grid, generator - with scalable, on-demand energy storage solutions for critical back-up and daily savings on electricity bills.

**FEATURES**



**Scalable for any energy need**

Virtually unlimited scalability to allow for longer-duration storage.



**Pair with leading inverters**

Ready to be integrated industry leading inverters for ease of installation.



**Lithium Ferro Phosphate (LFP) Chemistry**

Peace of mind that the elimination of cobalt reduces the risk of thermal runaway, fire propagation, operating temperature constraints, and toxic coolants.



**Leading safety-tested battery**

Certified to UL 9540 and UL 9540A Fire Safety Tested - ideal for lead acid battery replacement.

**48V Battery Voltage VS. Discharged Capacity**

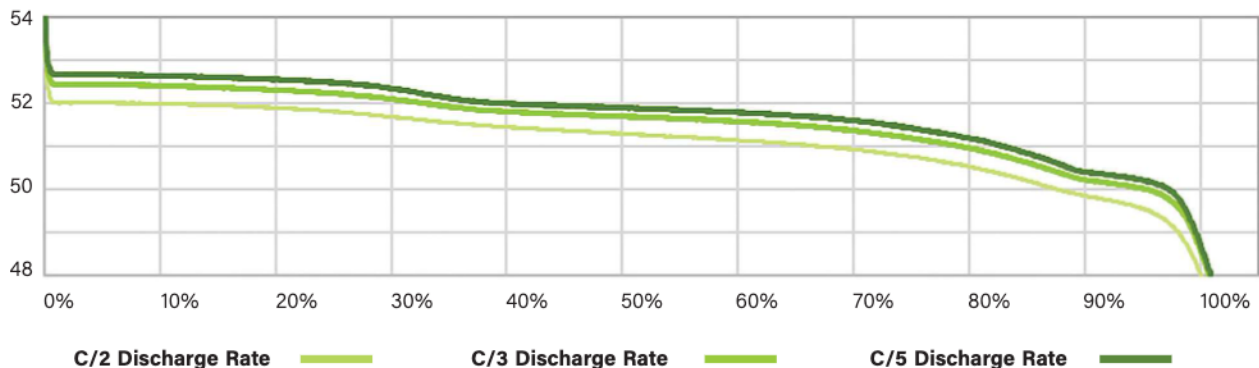

# 3.87

kWh

## PHI™ 3.8-M Battery



### BRIGGS & STRATTON ENERGY SOLUTIONS

| Specifications                          |  |                          |
|---|--|--------------------------|
| <b>Model Number</b>                     | PHI-3.8-24-M   | PHI-3.8-48-M             |
| <b>DC Voltage - Nominal</b>             | 25.6 VDC   | 51.2 VDC                 |
| <b>Amp-Hours</b>                        | 151 Ah   | 75 Ah                    |
| <b>Rated kWh Capacity</b>               | 3.87 <sup>1</sup> kWh DC @ 100% DOD<br>3.10 kWh DC @ 80% DOD   |                          |
| <b>Max. Discharge Rate (10 minutes)</b> | 80 Amps DC (2.05 kW DC)  | 80 Amps DC (4.1 kW DC)   |
| <b>Max. Continuous Discharge Rate</b>   | 75 Amps DC (1.9 kW DC)   | 37.5 Amps DC (1.9 kW DC) |
| <b>Max. Continuous Charge Rate</b>      | 75 Amps DC (1.9 kW DC)   | 37.5 Amps DC (1.9 kW DC) |
| <b>Certifications</b>                   | UN 3480, Lithium ion batteries, 9, II UL, CE, UN/DOT and RoHS compliant components - UL 1973, UL 1642, Certified to UL 9540, UL 9540A Fire Safety Tested |                          |
| <b>DC Voltage Range<sup>1</sup></b>     | 24 VDC to 28 VDC   | 48 VDC to 56 VDC         |
| <b>Depth of Discharge<sup>1</sup></b>   | Up to 100%   |                          |
| <b>Charging Temperature<sup>1</sup></b> | 32° to 120° F (0° to 49° C)  |                          |

| Specifications                           |   |
|--|---|
| <b>Operating Temperature<sup>1</sup></b> | -4° to 140° F<br>(-20° to 60° C)  |
| <b>Storage Temperature</b>               | 6 months: 14° to 77° F (-10° to 25° C)<br>3 months: -4° to 113° F (-20° to 45° C) |
| <b>Self-Discharge Rate</b>               | < 1% per month  |
| <b>Cycle Life</b>                        | 10,000+ cycles (@ 80% DOD)  |
| <b>RTE Efficiency</b>                    | 96%   |
| <b>Warranty</b>                          | 10 Years <sup>2</sup>   |
| <b>Terminals</b>                         | 3/8 IN (10 mm)  |
| <b>Battery Cables</b>                    | 6 AWG MINIMUM   |

| Product Dimensions            |   |
|-------------------------------|---|
| <b>Weight</b>                 | 86 lbs. (39.0 kg)   |
| <b>Dimensions (W x H x D)</b> | 13.5 x 14 x 8 in. (15.5" H w/terminals) / 0.88 ft <sup>3</sup><br>(34.3 x 35.6 x 20.3 cm / 0.025 m <sup>3</sup> ) |

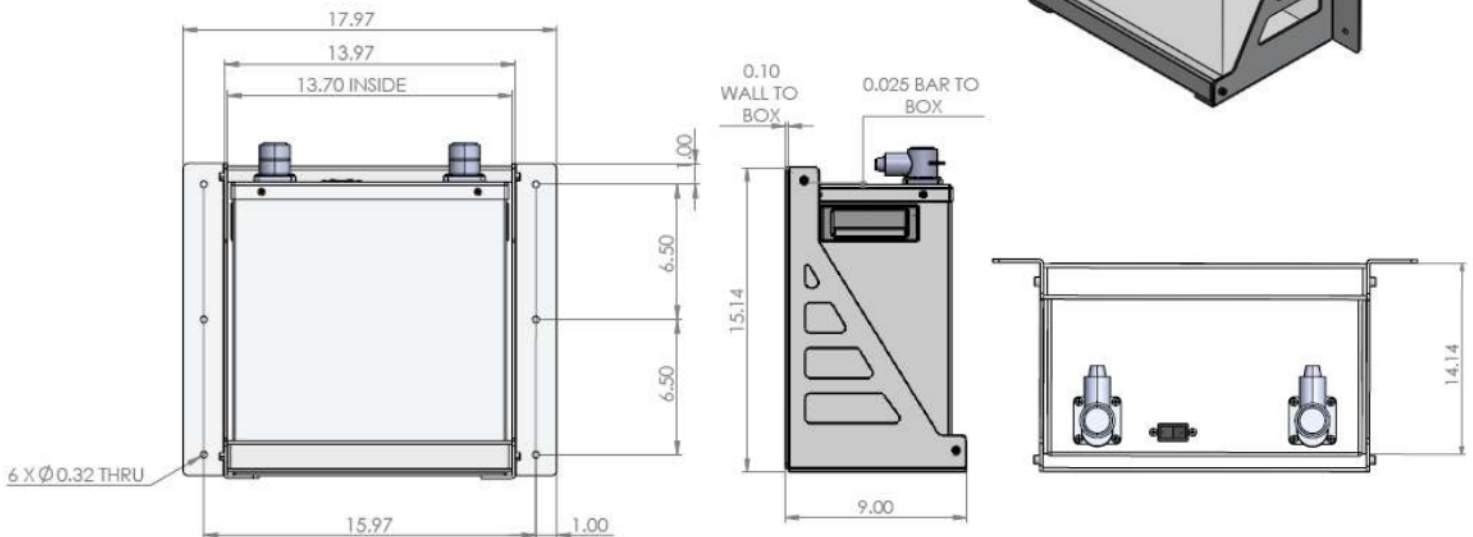
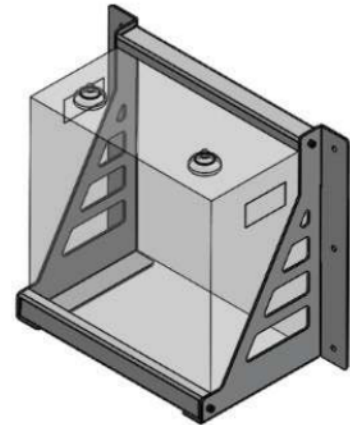

All specifications listed are typical/nominal and subject to change without notice.

<sup>1</sup> Maximum operating ranges. Refer to Installation Manual for recommended conditions.

<sup>2</sup> See operator's manual or [energy.briggsandstratton.com](http://energy.briggsandstratton.com) for complete warranty details.

Engineered and Manufactured in California, USA.

Briggs & Stratton has a policy of continuous product improvement and reserves the right to modify its specifications at any time and without prior notice. Please visit [BRIGGSandSTRATTON.com](http://BRIGGSandSTRATTON.com) for the latest information.

BS1397 - 8/23

**BRIGGS & STRATTON**  
POST OFFICE BOX 702  
MILWAUKEE, WI 53201 USA

Copyright © 2023 Briggs & Stratton. All rights reserved.